

**360 LIFECYCLE SERVICE  
AND SUPPORT**

**AUTOMATION  
& OPTIMIZATION**

**PACKAGED SYSTEMS**

**PUMPS**

**BOOSTERS**

**CIRCULATORS**

**FIRE SAFETY**

**REPLACEMENT  
PARTS**

Your guide to  
the complete line  
of Armstrong  
performance  
solutions



S.A. ARMSTRONG  
LIMITED

23

# BUILDING LIFECYCLE PERFORMANCE SOLUTIONS

---

FROM THE SMART  
BUILDING PERFORMANCE  
EXPERTS



**A** building doesn't move much, but it has to work. Every day. For decades. A building has to last. It has to withstand the elements and the ravages of time. It has to endure.

**Armstrong provides solutions to help buildings perform and endure.**

Just like a building that has to endure, our earth, our planet, also has to endure. Armstrong products and solutions help buildings and building owners minimize the environmental impact of their operations.

Armstrong Fluid Technology is known the world over as an innovator for designing, engineering and manufacturing intelligent fluid flow equipment, control solutions and digital technologies.

In the application of technology to mechanical systems for buildings, Armstrong is a change agent and a thought leader, taking mechanical systems to entirely new levels of operating efficiency.

Drawing on our experience and our history of service, Armstrong is able to serve a wide range of industries and contribute to mechanical systems in a diverse set of building types, supporting air conditioning, heating, commercial cooling, domestic water and fire safety systems.

5

**DESIGN ENVELOPE TECHNOLOGY**

Armstrong's innovative Design Envelope technology combines highest operating efficiency with lowest installed cost and lowest operating cost for your application.

7

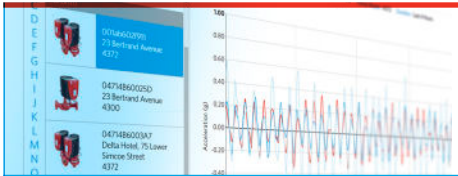
**ACTIVE PERFORMANCE MANAGEMENT**

From a single pump to an entire plant, Armstrong can help your system learn, predict and optimize performance at every level to make your project a success.

9

**360 SERVICE & SUPPORT**

Armstrong provides complete solution support to help you get the best possible performance from your mechanical systems, at every phase in the lifecycle of your building.

11

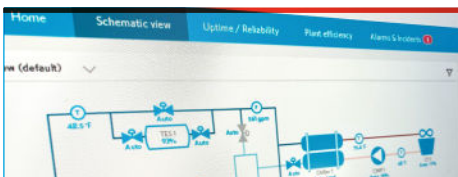
**AUTOMATION & OPTIMIZATION**

We offer a range of expert services to assist you in evaluating current operational equipment and energy efficiencies, as well as delivering complete ultra-efficient chilled water plants.

9

**PACKAGED SYSTEMS**

Pre-fabricated HVAC systems for chiller and boiler plants, pumping stations, energy transfer stations, cooling tower applications, fire pump systems, and water-based process applications.

**13 PUMPS**

Our expertise in demand-based control, fluid flow, variable speed, and heat transfer gives you the industry-leading outcomes you expect.

**19 BOOSTERS**

The most efficient and safest booster and water supply equipment, featuring cutting-edge capabilities such as soft fill, no-flow shutdown, and sensorless pressure optimization.

**20 CIRCULATORS**

Wet or dry rotor circulators that lead in reliability, ease of repair, and out-of-the-box energy savings. Armstrong circulators are a perfect match for installed based and many competing models.

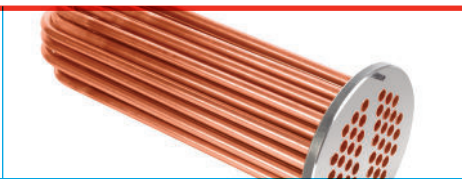
**22 HEAT EXCHANGERS**

High quality and durability combined with excellent heat transfer rates have placed Armstrong heat exchangers and tank heaters amongst the top in their categories.

**23 FIRE SAFETY**

Our proven and reliable fire safety pumps, controls, and packages meet the most demanding test standards and applications, available in diesel as well as electrical versions.

**25**

See our exciting new developments in replacement part kits and accessories

# DESIGN ENVELOPE



Design Envelope technology replaces mechanical components with electronics and software intelligence in order to:

**Boost energy efficiency**

**Downsize equipment**

**Optimize part-load performance**

As a design or building professional, this helps you achieve the lowest installed cost, lowest operating cost, and lowest environmental impact with your mechanical designs and installations. Design Envelope technology puts your projects at the sustainability forefront, in energy savings, cost savings, and carbon savings.

**ENERGY SAVINGS**

Savings for our clients' Design Envelope installations worldwide since 2007.

**1,050,989**

Tonnes of CO<sub>2</sub> equivalent\*

**1,813,782,505**

kWh electricity\*

\*as of April, 2021

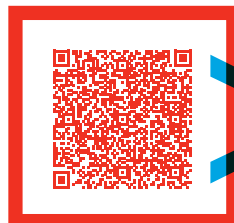

Scan to discover more benefits of Design Envelope technology for your new or retrofit project.

# FLAGSHIP EFFICIENCY

A COMMERCIAL FACILITY CASE STUDY



**LOWEST**  
ENERGY USE



**LOWEST**  
INSTALLED  
COST



**LOWEST**  
OPERATING COST

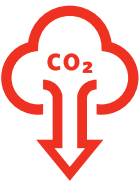

**LOWEST**  
CARBON  
EMISSIONS



**LOWEST**  
PROJECT &  
OPERATING RISK



## RBC Tower

A flexible HVAC system includes responsive HVAC controls that provide individual cooling at high efficiencies. The application draws on Toronto's Enwave deep lake water cooling system to dramatically reduce energy and operating cost.

The RBC Centre has achieved a

**50%  
ENERGY  
SAVINGS**

relative to similar towers built to standard code.



Scan to learn more about this case study.



OPTIMIZED EFFICIENCY  
AND PERFORMANCE

# ACTIVE PERFORMANCE MANAGEMENT™

---

LEARNS  

---

PREDICTS  

---

OPTIMIZES

With Active Performance Management at the plant level, you can save up to

**40%**

annual energy savings

Active Performance Management is a systems management approach that optimizes HVAC systems at any stage of a building's life-cycle by continuously learning from a broad network of installations and responding to changing HVAC requirements. The combination of smart commissioning with real-time alerts and system transparency addresses performance drift and maintains occupant comfort.

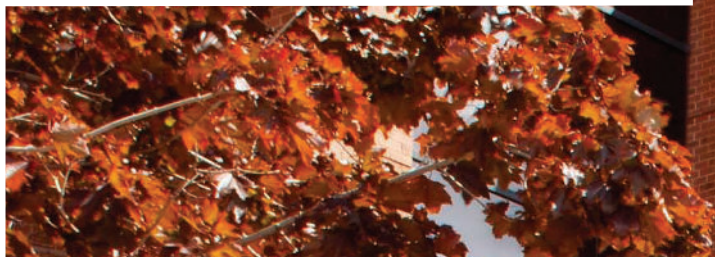

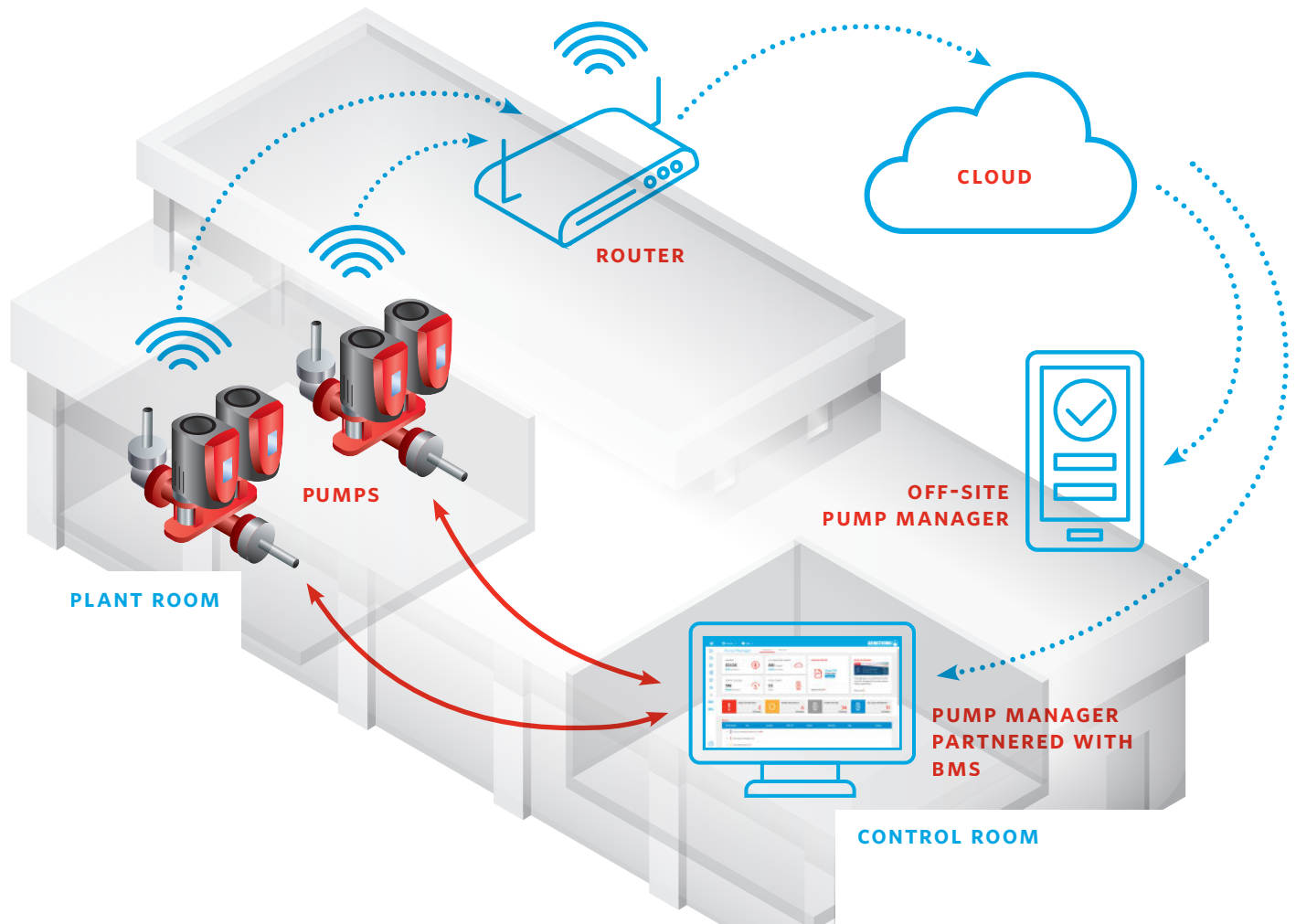

**SEE THE PRESENT  
KNOW THE FUTURE**

### **FLOW INFORMS**

The rate of fluid flow in an HVAC system is crucial to understanding how the different components are operating. Without information on system flow, it's difficult to diagnose and optimize performance. With accurate flow information, the picture changes entirely. Armstrong can optimize each component and the overall system.

We're there for the lifecycle of plant and equipment operations

Armstrong provides proven audit services that give you the most flexibility for equipment selection and right-sizing.

**DESIGN &  
CONSULTING**

Training, services and warranties for the lifecycle of your project, and kits that bring together the parts you need in one place.

**MAINTENANCE,  
REPAIRS &  
PARTS KITS**

Ease of replacement and modularity allow you to build a better solution that can be scaled.

**UPGRADES &  
PERFORMANCE  
ENHANCEMENT**

**360**



Rapid response attention

**MATCHED TO  
YOUR NEEDS.**

**+ 24/7 GLOBAL  
RAPID RESPONSE**



## CUSTOMER LIFECYCLE SUPPORT

### BUILD

Speed-to-market and quality are assured with modular, packaged systems.

### START-UP & COMMISSION

Armstrong offers a reduced timeframe, and energy savings from day one.

### OPERATE & OPTIMIZE

Our service plans ensure maximum equipment uptime through real-time performance management, informed system optimization and expert support for your building assets.



### Pump Manager™

Real-time operating insights and early diagnostic warnings

Full transparency in energy savings and carbon footprint reduction

Reduce pump maintenance cost by up to 50% with predictive maintenance

**U**ltimate system performance requires seamless integration of mechanical equipment, sensing and controls — with solid technical and logistics support. Armstrong HVAC control systems enable you to meet operating budgets, project schedules and environmental goals with a single point of supplier accountability.

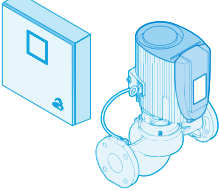
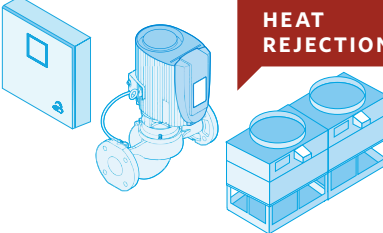
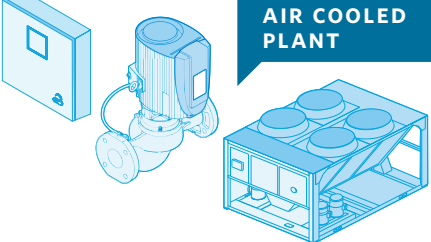
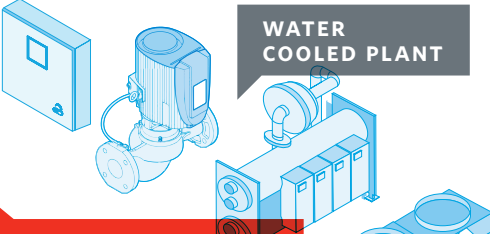
APPLICATION	EQUIPMENT	SOLUTION
<p><b>NOTE COLOUR CODING FOR APPLICATION-EQUIPMENT PAIRINGS</b></p> <p>↓</p>	 <p><b>PUMPING SYSTEMS</b></p>	<p><b>DESIGN ENVELOPE 4000 INTEGRATED PUMPING SYSTEM</b></p> <ul style="list-style-type: none"> <li>Advanced multi-zone control that directly integrates with pumping units to optimize energy performance, system handling, and installation</li> <li>Controls up to 8 pumps and 16 zones</li> <li>No limitations in system size and capacity</li> </ul>
<p><b>CHILLED WATER PLANT</b></p> <p>● ● ● ●</p> <p>Large and small scale facilities can both benefit from fully automated and optimized HVAC systems</p>	 <p><b>HEAT REJECTION</b></p>	<p><b>DESIGN ENVELOPE ITC 9521 INTEGRATED TOWER CONTROL SYSTEM</b></p> <ul style="list-style-type: none"> <li>Reduces energy rates</li> <li>Simplified tower automation and easy integration for improved system reliability</li> <li>Real-time flow metering accuracy and diagnostics to better understand your tower performance</li> </ul>
<p><b>ENERGY TRANSFER STATION</b></p> <p>● ●</p> <p>For cooling and heating applications in commercial spaces or for industrial applications</p>	 <p><b>AIR COOLED PLANT</b></p>	<p><b>DESIGN ENVELOPE 9511 INTEGRATED PLANT CONTROL SYSTEM</b></p> <ul style="list-style-type: none"> <li>Boosts energy efficiencies of new and existing chiller plant installations to class-leading levels</li> <li>Controls up to five chillers and five pumps</li> <li>Integrates with all brands of chillers, pumps, and automation systems</li> </ul>
<p><b>DATA CENTRE</b></p> <p>● ●</p> <p>For a data center market that evolves and as the pace of construction continues</p>	 <p><b>WATER COOLED PLANT</b></p>	<p><b>DESIGN ENVELOPE 9521 INTEGRATED PLANT CONTROL SYSTEM</b></p> <ul style="list-style-type: none"> <li>Boosts energy efficiencies of new and existing chiller plant installations to class-leading levels</li> <li>Integrates with all brands of chillers, pumps, and BAS</li> </ul>
<p><b>DISTRICT ENERGY</b></p> <p>● ● ● ●</p> <p>For buildings in municipalities and campuses that are dependent on district energy networks to meet their heating and cooling needs.</p>	<p>Optimize the system to unlock further efficiency with a set of recommendations that will serve as a roadmap for your upgrading system assets.</p>	<p><b>IPC 9521 + OPTIMIZATION</b></p> <ul style="list-style-type: none"> <li>Interfaces seamlessly with any existing building automation to maximize overall plant efficiency – without replacing or reconfiguring existing componentry</li> <li>A subscription-based patented self-learning optimization technology that enables efficiencies by creating the digital</li> <li>An optimization service that boosts energy and water savings, available as an upgrade for any previous installation of an Armstrong plant controller</li> </ul>
<p><b>BOILER</b></p> <p>●</p> <p>For industry professionals that are always searching for ways to improve their results.</p>		<p><b>DESIGN ENVELOPE EVERCOOL™</b></p> <ul style="list-style-type: none"> <li>Air-cooled or water-cooled chilled water system automation for data centers</li> </ul>

**A**rmstrong packaged systems deliver a variety of benefits to your project including:

- Reduced risk to project schedule
- Reduced risk of scope omissions and cost impacts
- Conformance to construction schedule
- Single point of supplier accountability
- Expert design for optimal performance

## CONFIGURATIONS

Modular plant rooms, chillers, boilers, boosters

Central utility plants

Intelligent fluid management systems

Fire pump houses

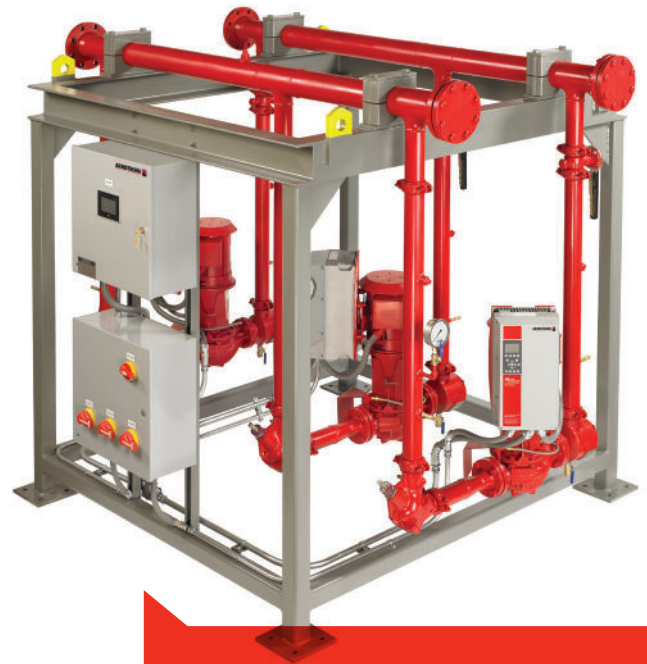

Sectors we specialize in:



INDUSTRIAL



DATA CENTRE



PHARMECEUTICAL & HEALTHCARE



RETAIL



GOVERNMENT



RESIDENTIAL



ENERGY SERVICES



SPORTING EVENTS



HOSPITALITY



EDUCATION



COMMERCIAL



TRANSPORTATION



AGRICULTURE



DISTRICT ENERGY

### FEATURE: DESIGN ENVELOPE INTELLIGENT FLUID MANAGEMENT SYSTEM

- Integrates pump and control technology into a single pumping solution yielding:
  - + compact footprint
  - + energy efficiency
  - + rapid installation
- Catalogue-based pre-engineered solutions or custom-designed to specification

With the maximum share of work completed in-factory, all that is needed for the completion of the project is to have the packaged plant connected on-site, Armstrong's packaged plants feature insulated structural design, matching or exceeding building code requirements.



**A**rmstrong pumps have been synonymous with superior design, reliability, maintainability, and operating efficiency. Design Envelope pumps deliver the lowest installed **and** lowest operating costs — resulting in the shortest payback periods compared to any other pumping equipment available in the market today.

MODELS AVAILABLE  
FOR PLUMBING AND  
POTABLE WATER  
APPLICATIONS

VERTICAL IN-LINE | SPLIT-COUPLED

- Pipe-mounted two-pump unit with integrated intelligent controls for space-saving installation
- Up to 900 USgpm flow; up to 160 ft head
- Temperature: 300°F
- Power: 1 hp to 10 hp
- Size: 1½" to 3"

DESIGN  
ENVELOPE



DESIGN ENVELOPE  
4322 TANGO PUMPS

VERTICAL IN-LINE | CLOSE-COUPLED

- Pipe-mounted two-pump unit with integrated intelligent controls and duty/standby operation
- Up to 900 USgpm flow; up to 160 ft head
- Temperature: 250°F
- Power: 1 hp to 10 hp
- Size: 1½" to 3"

DESIGN  
ENVELOPE



DESIGN ENVELOPE  
4372 TANGO PUMPS

- Pipe-mounted two-pump unit with integrated intelligent controls and duty/standby or parallel-pumping operation
- Up to 1250 USgpm flow; up to 250 ft head
- Temperature: 250°F
- Power: 1 hp to 75 hp
- Size: 3" to 8"

DESIGN  
ENVELOPE



DESIGN ENVELOPE  
4302 DUALARM PUMPS

- Pipe-mounted two-pump unit with integrated intelligent controls and duty/standby or parallel-pumping operation
- Up to 1000 USgpm flow; up to 140 ft head
- Temperature: 250°F
- Power: 1 hp to 7½ hp
- Size: 3" to 8"

DESIGN  
ENVELOPE



DESIGN ENVELOPE  
4382 DUALARM PUMPS

- Pipe-mounted UL 778 pumping unit with integrated intelligent controls for space-saving installation and superior energy performance
- 25 to 25,000 USgpm flow; 10 to 300 ft head
- Temperature: 300°F
- Power: 1 hp to 1250 hp
- Size: 1½" to 20"

DESIGN  
ENVELOPE



DESIGN ENVELOPE  
4300 PUMPS

- Pipe-mounted pump unit with integrated intelligent controls for space-saving installation and superior energy performance
- Up to 1000 USgpm flow; up to 140 ft head
- Temperature: 250°F
- Power: 1 hp to 10 hp
- Size: 1½" to 6"

DESIGN  
ENVELOPE



DESIGN ENVELOPE  
4380 PUMPS

## NEW DEPM PUMPS FOR OUTDOOR OPERATIONS AND HIGHER HORSEPOWER

Controls enclosure rated for UL Type 4X

Equipped with overhead shield to prevent pump from icing and overheating



A new 15 hp to 50 hp range of Design Envelope Permanent Magnet pumps deliver 20% lower operating costs than pumps with standard induction motors



HORIZONTAL

- Base mounted end-suction horizontal pumping unit with integrated intelligent controls for easier installation
- 25 to 4500 USgpm flow; 10 to 400 ft head
- Power: 1 hp to 125 hp
- Temperature: 300°F
- Size: 1.5" to 8"

DESIGN ENVELOPE



DESIGN ENVELOPE  
4200H

HORIZONTAL

- Motor-mounted pump unit with integrated intelligent controls for space-saving installation
- Up to 1000 USgpm flow; up to 125 ft head
- Power: 1 hp to 7.5 hp
- Temperature: 250°F
- Size: 1.5" to 6"

DESIGN ENVELOPE



DESIGN ENVELOPE  
4280

## CASE STUDY | National Grid



**FACILITY TYPE**  
Commercial office



**LOCATION**  
Solihull, Birmingham



**SIZE**  
Three-storey building



**ANNUAL ENERGY SAVINGS**

BUREAU VERITAS VERIFIED

**32%**



**ANNUAL ENERGY COST**

BEFORE	AFTER
£16,076	£10,866
GBP	GBP
AVERAGE	AVERAGE

**ANNUAL COST SAVINGS**

**£5,210** GBP

**A**rmstrong completed a project in the United Kingdom, retrofitting a building belonging to National Grid.

The retrofit included new pump sets that reduced energy consumption by 32%, saving over 5,000 GBP annually.

SOLUTION EMPLOYED

DESIGN ENVELOPE  
TANGO PUMPS



VERTICAL IN-LINE | SPLIT-COUPLED

- The Armstrong 4300 pipe-mounted pumps are designed for space-saving installation, high operating efficiency, and long service life
- Up to 28000 USgpm flow; up to 500 ft head
- Temperature: 300°F
- Power: 1 hp to 1250 hp
- Size: 1½" to 20"



4300 VERTICAL IN-LINE PUMPS

VERTICAL IN-LINE | CLOSE-COUPLED

- Integrated intelligent controls for space-saving installation and superior energy performance
- Up to 450 USgpm flow; up to 160 ft head
- Temperature: 250°F
- Power: 0.25 hp to 10 hp
- Size: 1" to 6"



4280 SINGLE-PHASE DEPM PUMPS



CASE STUDY | Bernardin Manor



ANNUAL ENERGY SAVINGS

74%



ANNUAL ENERGY COST

BEFORE	AFTER
\$5,872	\$1,547
CAD	CAD
AVERAGE	AVERAGE

ANNUAL COST SAVINGS

\$4,325 CAD

**B**ernardin Manor is an assisted living facility in Chicago. Armstrong proposed to upgrade existing constant speed pumps with new Design Envelope Tango pumps.

The three new, properly sized pumps are operating much more efficiently than the original pumps. Energy savings from the pump retrofit will be over \$4,000 per year.

SOLUTION EMPLOYED

DESIGN ENVELOPE

TANGO PUMPS



FACILITY TYPE  
Hotel



LOCATION  
Toronto, Canada



SIZE  
47 floors  
567 rooms

VERTICAL IN-LINE | SPLIT-COUPLED

- Pipe-mounted 2-pump units designed for space-saving installation and duty/standby operation
- Up to 1250 USgpm flow; up to 400 ft head
- Power: 1 hp to 100 hp
- Temperature: 121°F
- Size: 2" to 6"



4312 VERTICAL IN-LINE TWIN PUMPS

VERTICAL IN-LINE | CLOSE-COUPLED

- Pipe-mounted 2-pump units designed for space-saving installation and duty/standby operation
- Up to 1250 USgpm flow; up to 350 ft head
- Power: 0.33 hp to 60 hp
- Temperature: 250°F
- Size: 2" to 5"



4392 VERTICAL IN-LINE TWIN PUMPS



CASE STUDY

Texas Christian University



FACILITY TYPE  
Recreation centre



LOCATION  
Fort Worth, Texas



SIZE  
179,831 ft<sup>2</sup>



ANNUAL ENERGY SAVINGS

63%



ANNUAL ENERGY COST

BEFORE	AFTER
\$9,731	\$3,905
USD	USD
AVERAGE	AVERAGE

ANNUAL COST SAVINGS

\$7,581 USD

**W**ith enrollment of over 10,000 students per year, athletics is a key focus for TCU university, with the Horned Frogs competing in the Big 12 conference of the ncaas.

Armstrong approached TCU with a proposal to upgrade three constant-speed pumps in the Recreation Center. As a result of the retrofit project, TCU is saving over \$7,500 per year.

SOLUTION EMPLOYED

DESIGN ENVELOPE

END-SUCTION PUMPS



## VERTICAL IN-LINE | CLOSE-COUPLED

- The Armstrong 4360 pipe-mounted pumps are designed for space-saving installation and long service life
- Up to 350 USgpm flow; up to 200 ft head
- Temperature: 225°F
- Power: 0.33 hp to 15 hp
- Size: 1¼" to 3"



**4360 VERTICAL  
IN-LINE PUMPS**

- The Armstrong 4380 pipe-mounted pumps are designed for space-saving installation and long service life
- Up to 2500 USgpm flow; up to 300 ft head
- Temperature: 250°F
- Power: 0.33 hp to 60 hp
- Size: 1½" to 8"



**4380 VERTICAL  
IN-LINE PUMPS**

## HORIZONTAL

- Reduces cost across installation, operation, and lifetime maintenance. High-efficiency NEMA-premium motors ensure low energy consumption and cost
- Up to 5000 USgpm flow; up to 600 ft head
- Temperature: 250°F
- Power: 0.33 hp to 300 hp

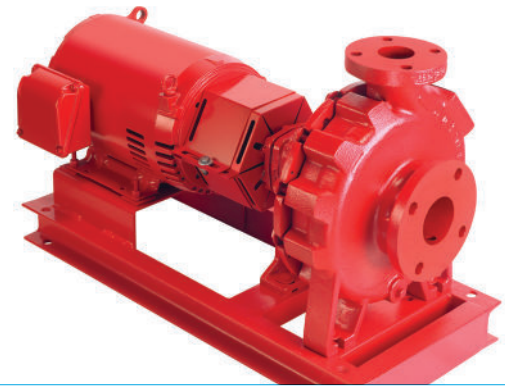

**4030 END  
SUCTION BASE  
MOUNTED PUMPS**

- End-suction pumps equipped with close-coupled motors to minimize footprint requirements
- Up to 2000 USgpm flow; up to 400 ft head
- Temperature: 250°F
- Power: 0.33 hp to 60 hp
- Size: 1" to 6"



**4280 MOTOR MOUNT-  
ED PUMPS**

- Close coupled horizontal pumps, motor mounted and designed for long service life and easy maintenance
- Up to 3600 USgpm flow; up to 130 ft head
- Temperature: 275°F
- Power: 0.33 hp to 60 hp
- Size: 1¼", 1½", 2"



**4270 & 4270 STOCK  
MOTOR MOUNTED  
PUMPS**

VERTICAL MULTISTAGE

- Designed for reliability and low maintenance cost
- Up to 400 USgpm flow; up to 900 ft head
- Temperature: 250°F
- Power: ½ hp to 50 hp
- Size: 1¼" to 4"



4700 VERTICAL MULTISTAGE PUMPS

HORIZONTAL

- Engineered to reduce cost across installation, operation, and lifetime maintenance. High-efficiency NEMA-premium motors ensure low energy consumption and cost
- Up to 7000 USgpm flow; up to 600 ft head
- Temperature: 225°F
- Power: 1½ hp to 500 hp

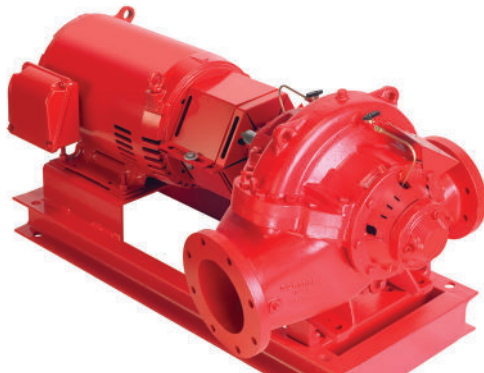

4600 HORIZONTAL SPLIT-CASE PUMPS



CASE STUDY | Pacific Mall

**FACILITY TYPE**  
Retail

**LOCATION**  
Ghaziabad, India

**SIZE**  
Large 4-storey commercial mall

ANNUAL ENERGY SAVINGS

**41%**

ANNUAL ENERGY COST

BEFORE	AFTER
\$233,613 USD	\$136,638 USD
AVERAGE	AVERAGE

ANNUAL COST SAVINGS

**\$96,975 USD**

Operations Managers asked Armstrong for help with replacing and upgrading three pumps that were over 10 years old and had begun to fail regularly.

Armstrong installed three Design Envelope Vertical In-Line pumps and used a datalogger to capture the energy usage. The replacement pumps doubled the energy savings estimate initially provided.

SOLUTION EMPLOYED

**DESIGN ENVELOPE**

VERTICAL IN-LINE PUMP



**D**esign Envelope Boosters combine advanced controls with NEMA Premium efficiency induction motors (IE3) and new DEPM (IE5) motors that surpass NEMA Super-premium efficiency. These designs optimize system-wide pressure boosting efficiency and reduce energy costs. Intelligent pump staging, automatic set-point adjustment and integrated variable frequency drives provide even greater savings. All Armstrong boosters are available in lead-free versions that meet the most stringent industry standards for potable water.

- Excellent all-purpose solution for applications requiring higher flowrates and boost pressures. Multiple pump configurations ensure design flexibility and ease of install and commissioning
- Up to 1962 USgpm flow; up to 320 psi
- Power: Up to 250 hp

**DESIGN ENVELOPE 6800 VERTICAL MULTISTAGE BOOSTERS**

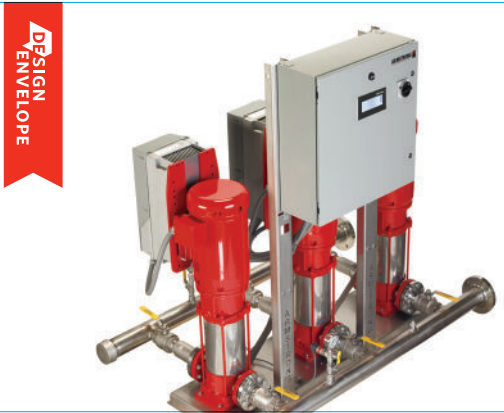

- The perfect solution for small and medium-sized applications. Compact design has the smallest footprint in the industry
- Up to 500 USgpm flow; up to 100 psi
- Power: Up to 40 hp

**DESIGN ENVELOPE 6900 VERTICAL BOOSTERS**



- The leading solution in the industry. DEPM motors with Design Envelope technology maximize efficiency, reduce noise and ensure reliability
- Up to 580 USgpm flow; up to 250 psi
- Power: up to 50 hp

**DESIGN ENVELOPE DEPM 6800G VERTICAL MULTISTAGE BOOSTERS**

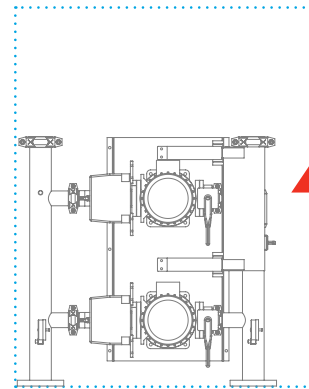

← Footprint of competing models

**MINIMAL FOOTPRINT**

**SPACE SAVINGS OF 25%**

**Design Envelope 6800\* 68" x 40"**

\* Including Permanent Magnet

**Competing models 77" x 48"**

DEPM motors provide a clear efficiency advantage across the operating range and the difference in efficiency levels is even greater at lower speeds.

- Reduced maintenance requirements**
- Longer uninterrupted operating times**
- Smaller size and reduced weight**
- Ultra-quiet operation**
- Larger range of operating speeds**
- Maximum design and installation flexibility**

MODELS AVAILABLE FOR PLUMBING AND POTABLE WATER APPLICATIONS

**T**he Armstrong Design Envelope Compass circulator embeds the latest motor and control technologies, providing you with the ultimate in flexibility, operating comfort, and energy efficiency. Our broad offering of wet-rotor and dry-rotor designs help you respond to any hydronic situation with ease and confidence.

### WET ROTOR DESIGN

- Designed to replace existing fixed speed circulators, with popular flange-to-flange dimensions. A universal replacement for all circulators in its capacity range
- Cast iron and stainless steel volutes
- Up to 20 USgpm flow; up to 20 ft head
- Power: 5W to 45W

**DESIGN ENVELOPE COMPASS H CIRCULATOR**

DESIGN ENVELOPE



### DRY ROTOR DESIGN

- Draws on advanced motor technology and efficient hydraulic design to achieve excellent wire-to-water duty point efficiencies
- Up to 140 USgpm flow; up to 60 ft head
- Temperature: 110°F
- Power: ¼ hp to ¾ hp
- Size: ¾" to 3"

**E.2 CIRCULATORS**



- Circulates water or ethylene-glycol solutions in closed hydronic or solar heating systems. Available in two volute materials for residential, small industrial, and commercial applications
- Up to 64 USgpm flow; up to 42 ft head
- Power: 33W to 218W

**ASTRO 2 CIRCULATORS**



- For commercial systems that require higher flow and pressure. Offers the flexibility of customizing the flow curve to specific application requirements
- Up to 250 USgpm flow; up to 55 ft head
- Temperature: 107°F
- Power: ¼ hp to 3 hp
- Size: ¾" to 3"

**1050/1060, 3-PIECE CIRCULATORS**



### DRY ROTOR DESIGN

- Designed to replace existing fixed speed circulators, with popular flange-to-flange dimensions. A universal replacement for all circulators in its capacity range
- Cast iron and stainless steel volutes
- Up to 140 USgpm flow; up to 40 ft head
- Power: ¼–½ hp

**DESIGN ENVELOPE COMPASS R CIRCULATOR**

DESIGN ENVELOPE



- For commercial systems that require higher flow and pressure. Offers the flexibility of customizing the flow curve to specific application requirements
- Up to 250 USgpm flow; up to 55 ft head
- Temperature: 107°F
- Power: ¼ hp to 3 hp
- Size: ¾" to 2"

**S&H 3-PIECE CIRCULATORS**



DRY ROTOR DESIGN

- A complete repair solution for the s&h circulator line. Armstrong PLVs can also be used to rebuild or upgrade select ITT/B&G circulator models
- Up to 120 USgpm flow; up to 60 ft head
- Temperature: 29°F
- Power: 1/2 hp to 2 hp

S&H CIRCULATOR  
LESS VOLUTE



WET ROTOR DESIGN

- A combination of circulator and low-flow (LF) valve that provides instant hot water in a residential plumbing system
- Up to 9 1/2 USgpm flow; up to 6 ft head
- Temperature: 40°F
- Power: 33W
- Size: 1 1/2" union

ASTRO EXPRESS 2 HOT  
WATER RECIRCULATION  
SYSTEM

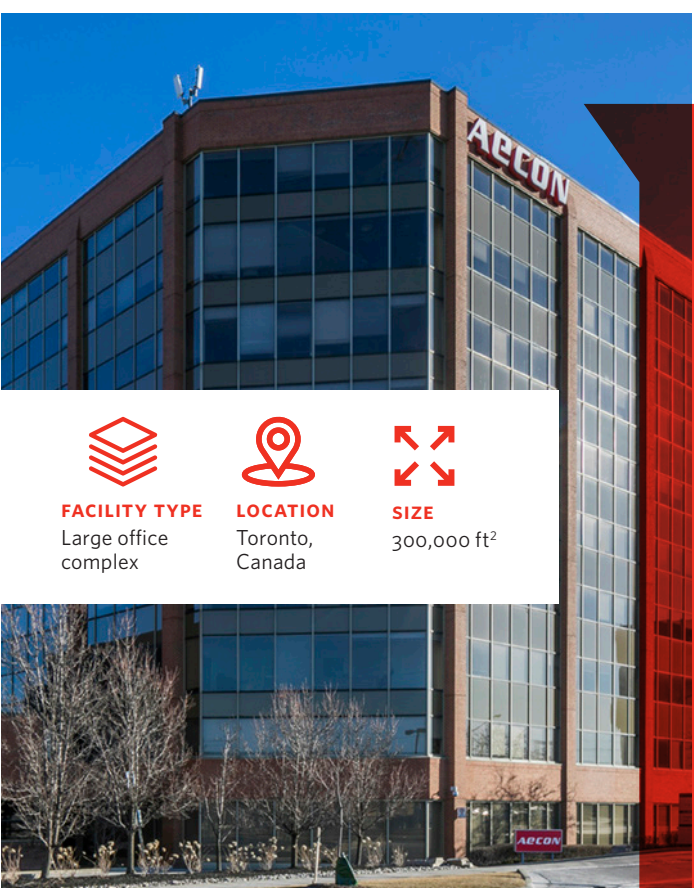

CASE STUDY | Crown Realty Parter Pearson Corporate

**T**his 300,000 square foot complex in Toronto consists of two eight-storey office towers joined together by a central atrium. In 2018 the building owners asked Armstrong to upgrade the original pumps to new Design Envelope pumps.

Armstrong's new Design Envelope variable-speed pumps produce energy savings of over 80%.

<b>FACILITY TYPE</b> Large office complex	<b>LOCATION</b> Toronto, Canada	<b>SIZE</b> 300,000 ft <sup>2</sup>



ANNUAL ENERGY SAVINGS

87%



ANNUAL ENERGY COST

BEFORE	AFTER
<b>\$140,072</b>	<b>\$18,380</b>
CAD	CAD
AVERAGE	AVERAGE

ANNUAL COST SAVINGS

**\$121,692** CAD

SOLUTION EMPLOYED  
**DESIGN ENVELOPE**

INTELLIGENT PUMPS WITH PUMP MANAGER



**H**igh quality and durability combined with excellent heat transfer rates have placed Armstrong heat exchangers and tank heaters amongst the top in their categories. In concert with other Armstrong equipment, Armstrong heat exchangers are a critical component for getting the maximum performance from your HVAC and fluid flow system.

- Suitable for use in any installation involving hot water boilers. The wide range of in stock models assures fast project turnaround
- In-stock selection covers applications from 0.5 USgpm to 160 USgpm. Larger models available for up to 600 USgpm



**ABX BRAZED PLATE  
HEAT EXCHANGERS**

- Provides dependable, efficient heat transfer in various applications ranging from HVAC to industrial installations. Armstrong Shell & Tube heat exchangers are suitable for higher-pressure applications in oil refineries and other large chemical processes



**SHELL & TUBE HEAT  
EXCHANGERS**

- Optimized for best water-to-water heat transfer providing enhanced performance especially in HVAC applications
- Performance range: 150 psi standard pressure rating. Pressure rating upto 435 psi available



**PLATE AND FRAME  
HEAT EXCHANGERS**

- Internal tube bundles designed for use with agitated or non-agitated tanks
- 150 psi standard pressure rating
- Temperature: 35°F to 375°F
- Size: 4" to 20"

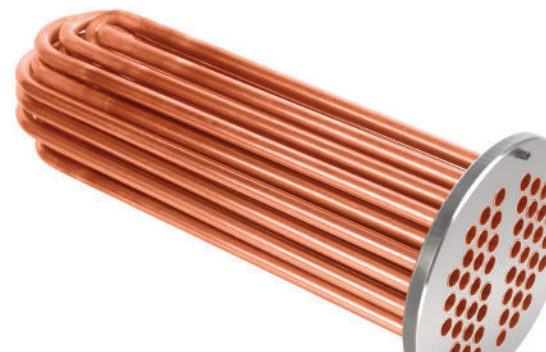

**TANK HEATERS**

**W**hen it comes to fire protection you can count on our track record of delivering reliable, durable and easy to test equipment and systems that are up to this critical task. Armstrong fire pumps and packages are constructed, tested and certified to the strictest global standards including NFPA, UL, ULC, and FM.

## FIRE PACKAGES

- Available as single electric, single diesel, one electric plus one diesel, two electric, or two diesel configurations. Optional features include tamper switches, test header lines, city by-pass and flow meter loops with all required piping and valves

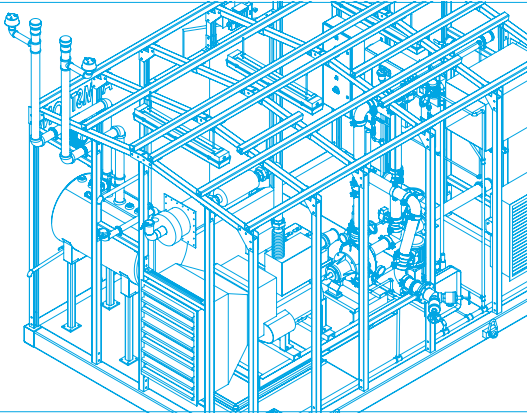

## ENCLOSED FIRE PUMP PACKAGES

- Features the full range of Armstrong HSC fire pumps, electric or diesel-driven, and controller. All mounted, piped, and wired on a base at the factory
- Up to 3000 USgpm



## FIREPAK HORIZONTAL SPLIT CASE

- Features the full range of VIL fire pumps with electric motor and controller. All mounted, piped, and wired on a base at the factory. The complete package is designed to fit through a standard door
- Up to 1500 USgpm



## FIREPAK VERTICAL IN-LINE

## FIRE PUMPS

- Deploys a heavy-duty bearing frame to provide long and reliable service in an over-hung impeller design. Eliminates the design layout constraints imposed by horizontal split-case pump configurations
- Up to 1750 USgpm

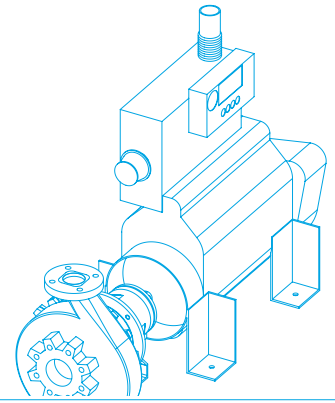

## FIRESET END SUCTION DIESEL &amp; ELECTRIC

- Deploys a tilted parting design, with the casing of each pump split at a 15° angle. This maximizes efficiency by minimizing turbulence at the impeller eye
- Up to 3000 USgpm

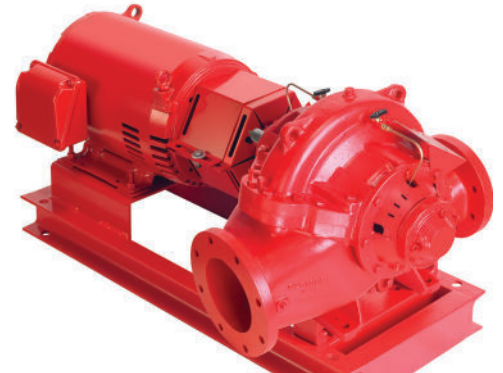

## FIRESET HORIZONTAL SPLIT CASE DIESEL &amp; ELECTRIC

- Ideal for applications where space is at a premium. The vertical in-line design saves up to 60% of floor space compared to equivalent horizontal split-case installations
- Up to 1500 USgpm



## FIRESET VERTICAL IN-LINE

FIRE PUMPS

- Designed for reliability and low maintenance cost
- Up to 400 USgpm flow; up to 900 ft head
- Temperature: 250°F
- Power: ½ hp to 50 hp
- Size: 1½" to 4"



4700 VERTICAL MULTI-STAGE PUMPS

FIRE PUMPS

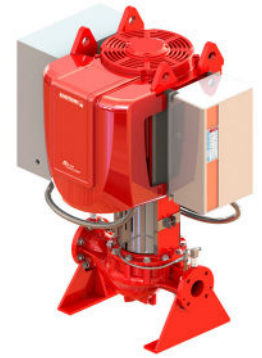

- Factory-built integrated fire pump unit consisting of pump, driver, and variable speed control unit, configured to maintain the set pressure until the maximum power draw
- Up to 1500 USgpm
- Max. ambient temperature: 50°F+
- Power: 20 hp to 250 hp

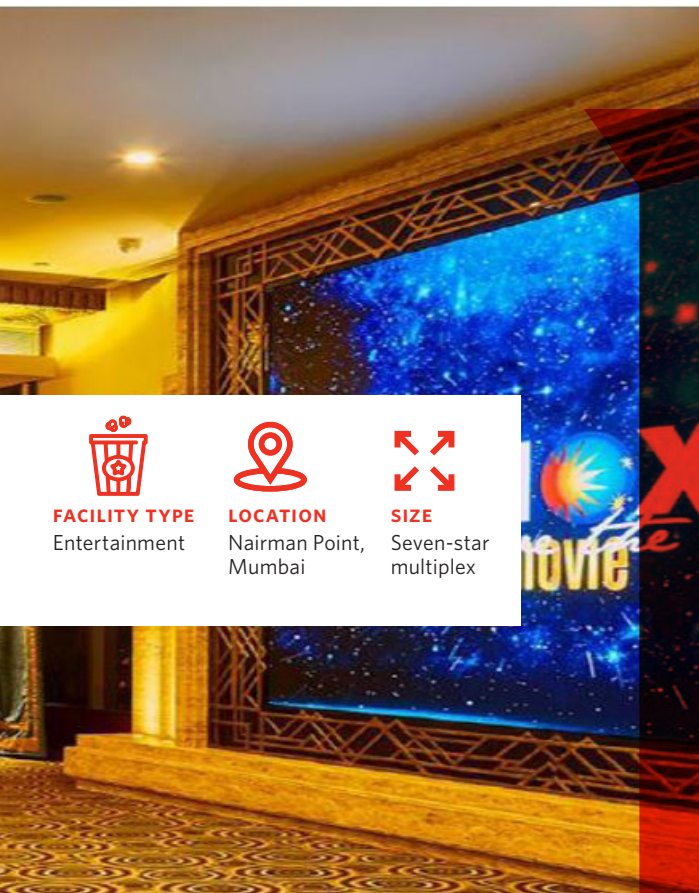

DESIGN ENVELOPE FIRE PUMP



CASE STUDY | INOX Leisure Limited

		
<b>FACILITY TYPE</b> Entertainment	<b>LOCATION</b> Nairman Point, Mumbai	<b>SIZE</b> Seven-star multiplex



ANNUAL ENERGY SAVINGS

43%



ANNUAL ENERGY COST

BEFORE	AFTER
<b>\$18,215</b>	<b>\$10,308</b>
USD	USD
AVERAGE	AVERAGE

ANNUAL COST SAVINGS  
**\$7,907** USD

**T**his leader in India's cinema industry asked Armstrong to replace four constant-speed pumps with three Design Envelope pumps, and changed their system to use primary-variable control.

HVAC savings as a result of the retrofit project were over \$7,900, which represented a 43% decrease in spending year-over-year. The payback period for the investment in energy efficiency was just 1½ years.

SOLUTION EMPLOYED

**DESIGN ENVELOPE**

VERTICAL IN-LINE PUMP



**E**ven the best equipment and installations require attention from time to time. Genuine factory parts keep your Armstrong equipment and systems operating reliably with a long service life — the way they were originally designed for. Call our Field Assistance at +1 416 755 2298 or your local authorized Armstrong Service Dealer.

## FEATURE REPLACEMENT PART: DROP-IN UPGRADE

The Design Envelope Vertical In-Line Retrofit Solution lets you upgrade a constant speed pump to an intelligent, Sensorless, variable speed solution

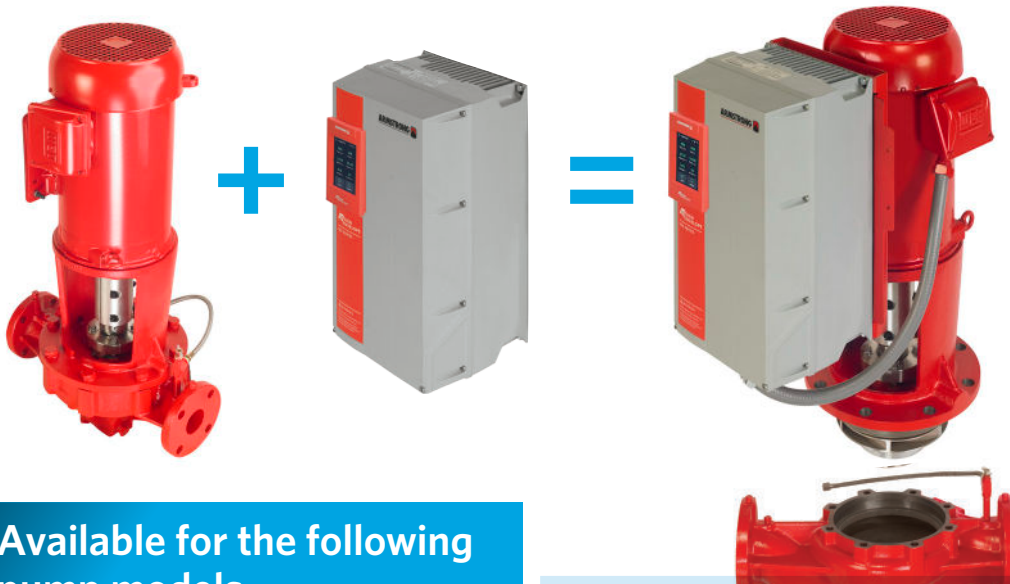

Available for the following  
pump models

[4300/4380 Vertical In-Line pumps](#) | 132 pump models in 14 casing sizes

[4312/4392 Vertical In-Line Twin pumps](#) | 39 pump models in 7 casing sizes

[4302/4382 Vertical In-Line dualArm pumps](#) | 59 pump models in 9 casing sizes

All VIL Retrofit units are performance tested using a matching casing.

ARMSTRONG PARTS KITS:  
ENGINEERED AND PRE-ASSEMBLED

**A**rmstrong Parts Kits are engineered combinations of genuine replacement parts — planned, selected and packaged based on solution types and sizes. Use Parts Kits for maintenance projects to add value to your building operators and service personnel.



CASE STUDY | Commercial Towers

**T**he owners of this pair of commercial towers recently completed an hvac upgrade, replacing three constant speed pumps with new Design Envelope pumps with Pump Manager.

Along with the energy savings, Pump Manager provided system warnings that helped avoid expensive repairs and energy losses.

**FACILITY TYPE**  
Commercial office tower

**LOCATION**  
Toronto, Ontario

**SIZE**  
18 floors, 20,000 ft<sup>2</sup> per floor



ANNUAL ENERGY SAVINGS

77%



ANNUAL ENERGY COST

BEFORE	AFTER
\$68,185	\$15,918
CAD	CAD
AVERAGE	AVERAGE

ANNUAL COST SAVINGS  
**\$52,267** CAD

SOLUTION EMPLOYED

DESIGN ENVELOPE

VERTICAL IN-LINE PUMP



**T**o make sure you get the best possible results from your mechanical room designs and installations we carry an assortment of high-quality ancillary products. By using Armstrong accessories you can be certain no quality low points and operating bottlenecks get in the way of your system performance.

- Multi-function pump fittings that provide a 90° elbow, guide vanes, and an in-line strainer. Suction guides reduce pump installation cost and floor space requirements
- Suitable for all Armstrong commercial pumps and pumping systems
- Size: 1½" to 20"

DESIGN  
ENVELOPE



#### SUCTION GUIDES

- Designed to eliminate trapped air and suspended dirt particles associated with the start-up and maintenance of hydronic and HVAC systems



#### DIRT & AIR SEPARATORS

- Multi-function pump fittings that reduce equipment and installation costs
- Suitable for all Armstrong commercial pumps
- Size: 1½" to 20"

DESIGN  
ENVELOPE



#### FLO-TREX VALVES

- Provide automatic glycol make-up for HVAC systems. The specially molded mixing tank offers a compact package with built-in housing for controls and make-up pump
- Suitable for all bladder and compression tanks up to 90 psi (621 kPa) cold-fill pressure



#### GLYCOL AUTOFILL UNITS

- Designed to reduce tank sizes by up to 80% over standard designs
- Range: AET plain steel expansion tanks: 15 to 525 US gal. capacity; AX diaphragm expansion tanks: 8 to 211 US gal. capacity; Type L bladder type expansion tanks: 10 to 1056 US gal. capacity



#### EXPANSION TANKS

- ½" to 2" models feature multi-turn adjustment for precise control, hidden memory stops to set balance point and soft seats for positive shutoff
- Temperature: -4°F to 300°F
- Size: ½" to 2"

**CIRCUIT BALANCING VALVES (½"-2")**



- Built with high-quality materials for premium energy-efficiency and long service life
- Designed for class B temperature rise and equipped with superior class F insulation. Maximum ambient temp 40°C (unless approved differently)
- Power: 0.33 hp to 1250 hp

**MOTORS**



- 2½" to 12" models feature multi-turn adjustment for precise control, hidden memory stops to set balance point and soft seats for positive shutoff
- Temperature: 230°F
- Size: 2½" to 12"

**CIRCUIT BALANCING VALVES (2"-12")**



**CASE STUDY | Delta Hotel**

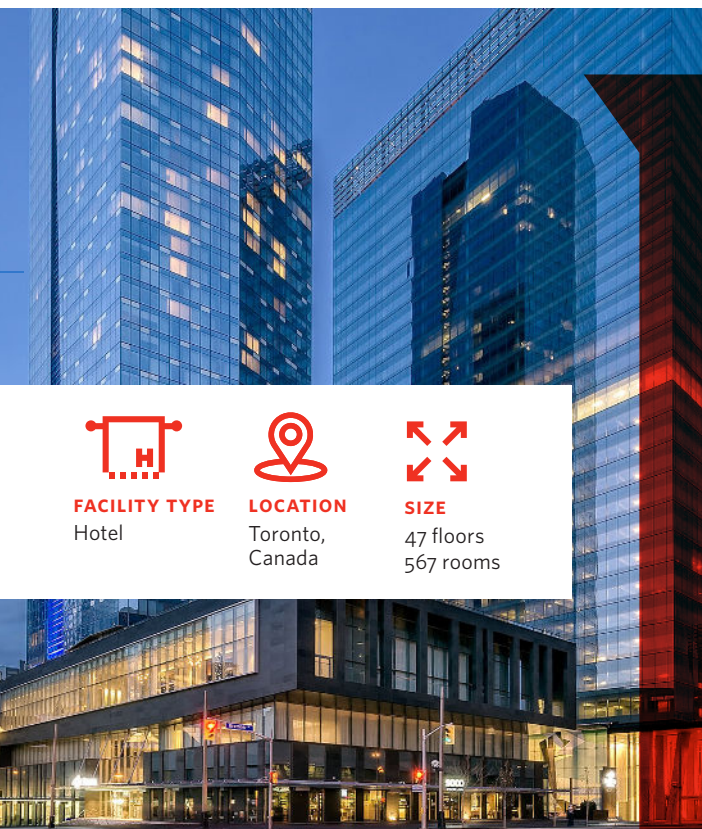

**FACILITY TYPE**  
Hotel



**LOCATION**  
Toronto, Canada



**SIZE**  
47 floors  
567 rooms



**ANNUAL ENERGY SAVINGS**

**40%**



**ANNUAL ENERGY COST**

BEFORE	AFTER
\$5,659	\$3,364
<small>CAD</small>	<small>CAD</small>
<small>AVERAGE</small>	<small>AVERAGE</small>

**ANNUAL COST SAVINGS**  
**\$1,700<sup>CAD</sup>**

**D**elta Hotels Toronto commissioned an upgrade of one of their existing pumps to a new Design Envelope Tango. Energy savings post-installation have proven that the Tango pump was the right choice.

Savings from upgrading just one pump will be over \$2,000 per year. Total energy savings will be 22,000 kWh, a 40% improvement.



**SOLUTION EMPLOYED**

**DESIGN ENVELOPE**

**TANGO PUMPS**

 our core expertise of fluid flow, energy transfer, demand-based control and digitalization mitigates risk and reduces complexity. Armstrong harnesses fluid flow and energy transfer expertise to simplify the complexities of a heating and cooling system to deliver resilience.

We then leverage digitalization and demand-based controls to achieve optimal asset utilization and reducing overall construction costs — while maximizing occupant comfort, performance and resiliency throughout the lifecycle of the building.

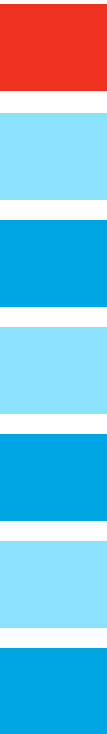
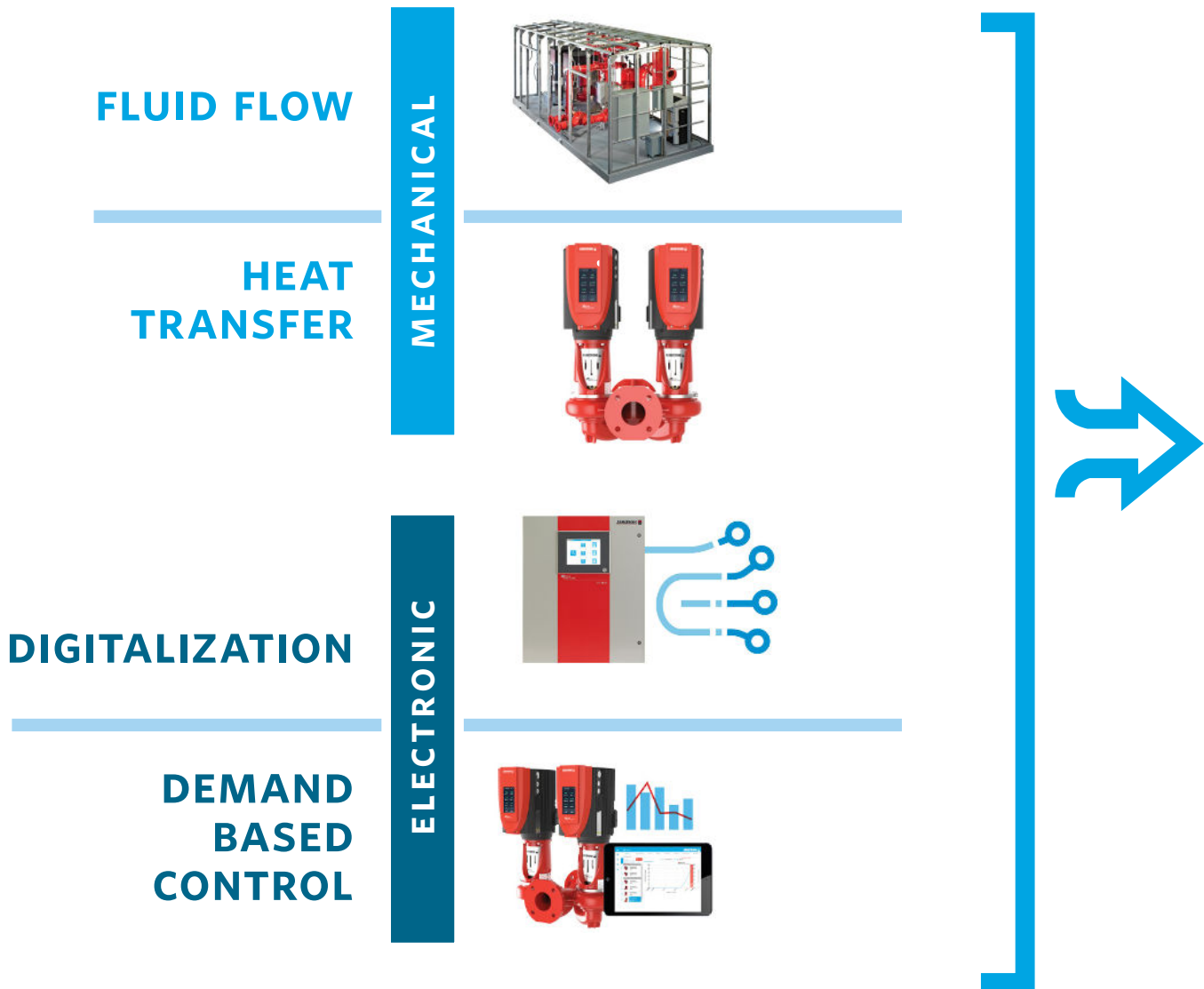



**Lifetime building performance**

**Reduced construction costs**

**Reduced operating costs**

**Reduces CO<sub>2</sub> emissions**

**Increased sustainability**

**Enhanced occupant comfort**

**Optimal asset utilization**

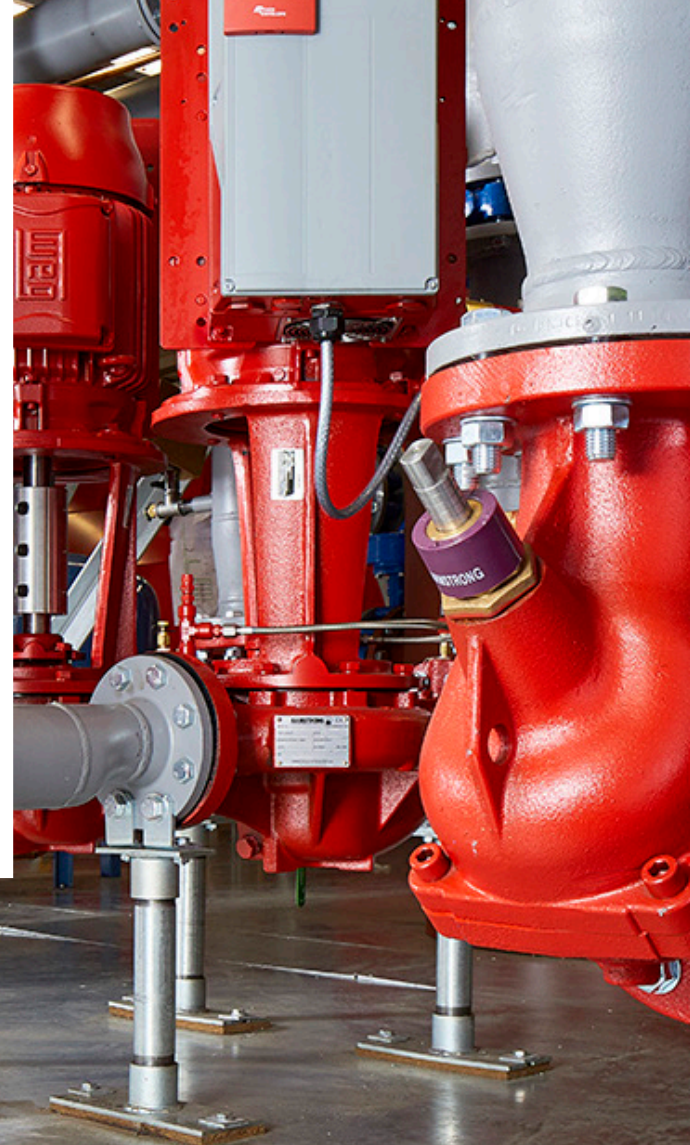

## WHY USE VERTICAL IN-LINE (VIL) PUMPS VS. HORIZONTAL DESIGN?

### HORIZONTAL DESIGN

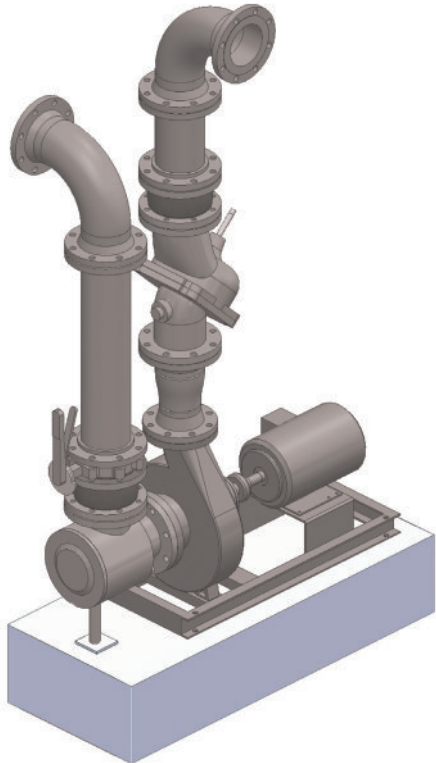

### VERTICAL IN-LINE

Reduced footprint (typically 46% of equivalent horizontal design)

No requirement for concrete pad

No requirement for isolation mount and springs

No requirement for axle alignment after seal change (VIL is self-aligning)

Rapid seal changes (typical 20 minutes with one person)

Ultra-smooth operation with minimal vibration

Reduced pipe runs

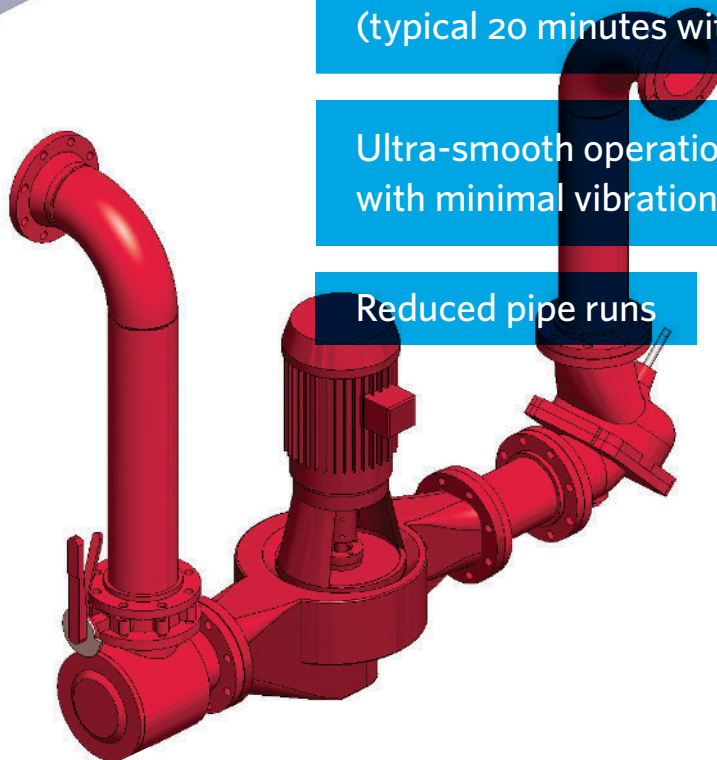

## WHY USE DESIGN ENVELOPE INTEGRATED CONTROLS VS. WALL-MOUNTED DRIVES?

### WALL-MOUNTED DRIVE

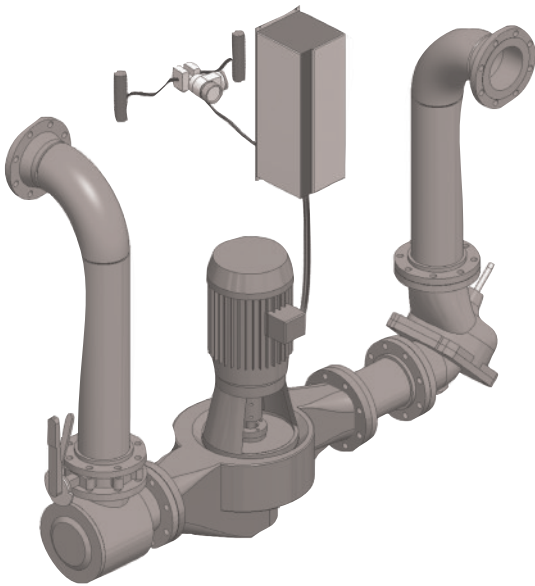

### DESIGN ENVELOPE

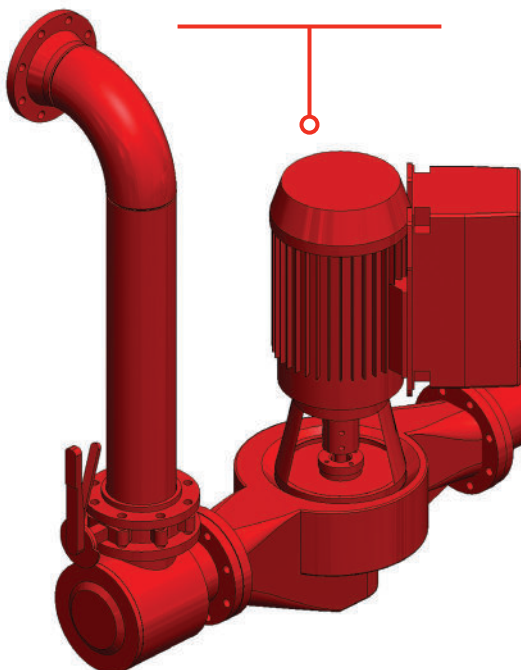

### DESIGN ENVELOPE INTEGRATED CONTROLS

Minimal project and operating risk through three-year warranty on controls and pump

Single point of supplier accountability

Factory tested and configured

Superior energy efficiency and envelope control compared to “non-native” controls (such as wall-mounted drives)

Integrated 5% line isolation (no need for separate transformer)

Elimination of grounding rings (optional in case of concern)

Outdoor option up to 125 HP (no enclosure required)

Elimination of wiring (power and control) between pump and wall-mounted drive

Elimination of differential-pressure sensor as well as associated wiring and labor (in case of concern Design Envelope can read sensor input)

# What makes Armstrong different?

---

No other company integrates demand-based controls, heat transfer, fluid flow and variable speed as well as Armstrong, adding value to your project.

---

Only Armstrong has patented, award-winning, proprietary Parallel Sensorless pumping technology, delivering unmatched efficiency with multiple pumps.

---

Armstrong's integrated capability offers unmatched scalability and flexibility, opening up significant application opportunities.

---

**Only Armstrong offers intelligent, self-aware and self-optimizing solutions that combine to deliver optimum building performance.**

---

**Only Armstrong can deliver both the lowest installed cost AND the lowest operating cost time after time.**

---

**Only Armstrong factory tests and programs each unit, resulting in the accuracy and repeatability of all our solutions from custom large plants to small components.**

---

**Armstrong is privately held, allowing us to take a long-term perspective on the success of your project.**

## WHERE TO BUY

---

Armstrong products, services, and replacement parts are available nationwide from our authorized representatives, distributors, wholesalers, and service dealers.

---

Visit [ArmstrongFluidTechnology.com](https://www.armstrongfluidtechnology.com) to find your local representative

